

Patch Panel Antennas

1880-1900 Mhz, 10dBi Gain, Patch Antenna

Product Description:

Patch Antenna's are quite directional as they have most of their power radiated in one direction in both the vertical and horizontal planes. It's flat design provides high efficiency and low back lobes with minimal depth dimension.

Applications:-

Outdoor long range point to point connection.

Features:

- Compact in Size
- Field Proven
- Easy to install
- Cost effective
- Linear Polarization

Electrical Specifications:

Model No.	PA18010N01
Frequency Range (Mhz)	1880-1900
Return Loss (dB)	>15
Power (Watts)	50
Impedance (ohms)	50
Gain (dBi)	10
Polarization ration	Horizontal / Vertical
Front to Back ration (dB)	18
H.P.B.W	50°

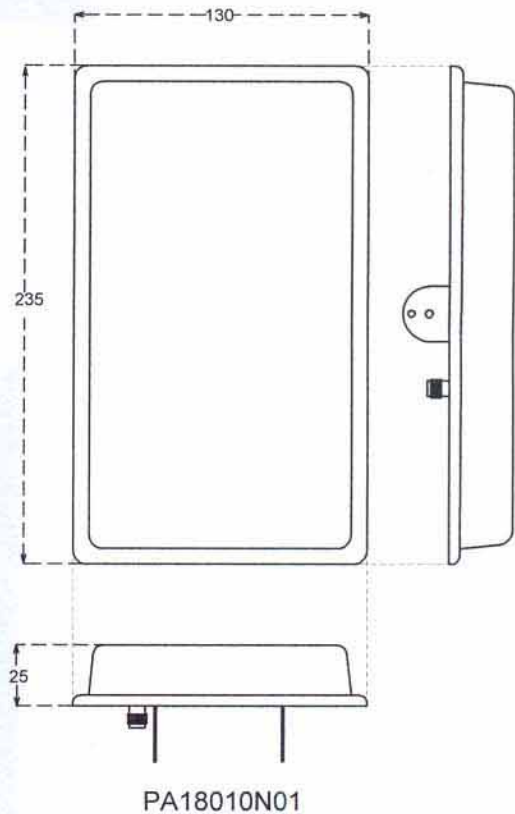

Mechanical Specifications:

Connector	N (Female)
Mounting Hardware Material	MS
Unit dimension (LXWXH)mm	200X130X235
Unit weight (Kgs)	0.5
Unit Packed Dimension (LXWXH)mm	250X150X70
Unit Packed weight (Kgs)	0.7
Radome Material	ABS Glass filled with UV Protection

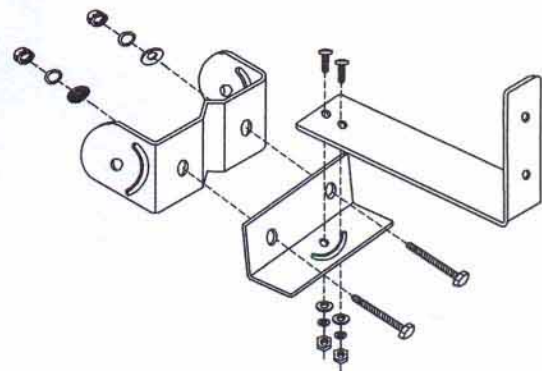

fig: Mounting Guide

Due to continous improvement policy and efforts, dimensions are subject to change for further improvement.